



**SOLAR ASSISTED  
MINI SPLITS**

**SOLAR ASSISTED  
VRF**

# **YMGI SOLAR Products**

**FEATURES & SPECIFICATIONS**

**YMGI Group**

601 Arrow Ln, O'Fallon, MO 63366 • 866-833-3138 | info@ymgigroup.com • ymgigroup.com

# WELCOME



## YMGI's Commitment to Energy Efficiency and Solar Energy!

### Where Comfort and Performance Live in Perfect Harmony.

YMGI is dedicated to quality, reliability and comfort. Just as great orchestras work in harmony to realize a perfect performance, so do YMGI products and customer service. YMGI offers products that provide quiet and clean heating and cooling. Enjoy the healthier air, energy savings and peace of mind.

### Efficient, Reliable, and Stylish

YMGI products quickly and quietly cool and heat your environment in the most efficient way possible. Both the indoor and outdoor unit have a contemporary style, with a sleek shape and an attractive neutral color. Most importantly, our systems are engineered and built with quality parts that offer reliability and longevity. YMGI stands behind our products and work to ensure our customers are completely satisfied with their YMGI ownership experience.

### Meet the Symphony Conductor

As a leading manufacturer of green HVAC technologies, YMGI strives to design products that create harmony between our customers and their environments. YMGI designs, manufactures and sells air conditioners and heat pumps for use in residential, institutional, hospitality, light commercial, and industrial applications. Our HVAC and refrigeration products offer the best value available and are friendly to the environment, contractors and end users.

### A Talented Ensemble Working in Perfect Harmony

YMGI's R&D team consists of highly trained and experienced professionals, striving to create new and improve existing HVAC technologies. Our lab team test our designs and components for quality and longevity. Our Quality Assurance teams tightly control all aspects of part manufacture, equipment assembly, unit inspection and shipment.

## Discover *Maximum Comfort.*

YMGI is committed to protecting the environment by offering a large selection of Solar Assisted HVAC products.

**YMGI is the BEST Value in State-of-the-Art HVAC Products.**



## Table of Contents

### Introduction

#### About SOLAR ASSISTED MINI SPLITS

- Introduction to Solar Minisplits
- Benefits
- Features
- Specifications

#### About All DC SOLAR MINI SPLITS

- Benefits
- Specifications

#### About SOLAR ASSISTED VRF

- Introduction to VRF
- Benefits
- Features
- Specifications

#### YMGI Advantages

- Ease of Installation
- Technical Support
- Customer Service
- Warranty Overview
- Credentials and Certification
- Tax Credits

### Meet the Symphony Performers

The YMGI Solar Series are available in single zone mini-split and multi-zone mini-split and modular systems.

The Symphony (56) series consists of one outdoor condensing unit and one wall mounted indoor unit. A system designed to heat and cool smaller single zone spaces like sunrooms, nurseries, studio apartments, offices and mobile homes.

The VRF SOLAR SERIES offers support for multiple indoor units, and can be installed to offer simultaneous heating and cooling. Designed to heat and cool larger spaces, such as houses, stores, gyms, libraries, hotels, galleries and restaurants.

The YMGI SOLO and CHOIR Symphony systems utilize the latest inverter technology. They deliver just the right amount of cool or warm air, more efficiently than conventional central air systems.



# SOLAR MINI SPLIT

## A Smart Heating And Cooling Solution

Mini-split systems are the easiest and simplest cooling solution for additions to existing homes, or older homes that have been built with non-ducted heating systems, like hot water heat, radiant heat or space heaters. They are a great solution for both new construction and retrofit or remodeling jobs. YMG Symphony mini-split ductless air conditioning and heat pump systems are designed to heat and cool quickly, quietly and efficiently.

Mini-splits are ideal for room additions and newly enclosed spaces such as sunrooms, garages, sheds and pool houses that cannot be connected to the main central air conditioning system, or where extending or installing ductwork would be time consuming, costly, or even not possible.

## How Mini-split Systems Work:

### The Differences between Central Air and Mini-split Systems

All air conditioning systems consist of an outdoor condensing unit and an indoor evaporator unit. The basic difference between a mini-split and central system is that the evaporator unit of the central system is commonly installed in the basement or attic and uses metal or fiberglass ductwork to deliver warm or cool air to different rooms in your home. A central system requires space inside the walls between the joists for the ductwork, plus floor/wall/ceiling space to install the registers. These systems are often noisy and the ductwork is a haven for dust, germs, mold, bacteria, and insects.

The mini-split system is totally ductless. The indoor unit is mounted in the room you want to heat or cool, so no ductwork is required. The outdoor and indoor units are connected with small refrigerant copper pipes and wires that are wrapped tightly and securely through a 3" opening in the wall. Installation is faster, and easier than a conventional ducted system.



The mini-split's compressor (found in the outdoor condensing unit) pumps refrigerant through the condensing coils and the metering device to the indoor unit where a fan blows across the coil to cool the room.

Remarkably, in heat pump mode, the same unit absorbs heat from the outside air and moves it indoors to heat the room. For most climates, this results in efficient, heating and cooling, keeping you comfortable all year long.



## Maximum Comfort, Minimum Cost

A conventional forced air cooling or heating system uses an “on and off” cycle. When a conventional system starts running, it runs at its top speed, consuming the maximum amount of energy in order to reach the desired temperature. The system then has to cycle between on and off, in an effort to maintain the set temperature. The continual starting and stopping of the major components in a conventional air conditioning system reduces the life span of the compressor and other components.

YMGI’s mini-splits use a DC Inverter to convert alternating current (AC) to Direct Current (DC), modulate pulse width, and then direct the inverted current back to alternating current (AC) at the optimum frequency, giving precise control over the operating speeds of the electric motors and compressor. Our Symphony Series Mini-split DC Inverter system, allow your system to start slowly and smoothly, and then accelerate to higher speeds to quickly bring the room to the desired temperature. Once the set temperature is reached, the system slows and adjusts itself to counter the heat gain or loss of the building, maintaining a consistent temperature. Delivering maximum comfort at minimum cost.

## Easy to Operate and Easy To Live With

Each YMGI mini-split indoor unit come with a remote control, that lets you select the operating thermal mode, fan speed, and oscillation of the air louvers, giving you total control of your environment. The remote also lets you program the start and stop time, and desired temperature. YMGI mini-split indoor units operate quietly, and have horizontal or vertical air directional louvers to evenly distribute conditioned air throughout the entire room. The outdoor units feature quiet operation, horizontal venting and a contemporary look.

## Products Perfect for Any Decor

YMGI SOLO and CHOIR systems offer a complete line of indoor units to cool or heat your rooms. From our attractive EW wall mounted units, that complement any décor, to our flush mounted EC ceiling cassette units that seamlessly blend into suspended ceilings, to our recessed ceiling mount EF units that virtually disappear; YMGI has indoor units that suit your needs and your taste.

The advantages of mini-split systems aren’t just on the inside. Most central system outdoor units are up-flow, which means the condenser fan is pointed upwards. Because of this, the outdoor units need more installation room. A mini-split system’s outdoor unit is horizontal flow, with the fan pointed sideways. Because it requires less room, a mini-split can be placed where installation of a central air system would not be possible. A mini-split can be installed on a concrete pad, a balcony or below a deck, making them ideal for metropolitan areas, where space between buildings can be very tight.

# BENEFITS

## Models & Features to Meet Any Need

YMGI offers a wide selection of DC Inverter mini-split systems. SOLO single zone units from 9,000 to 36,000 Btu/h and CHOIR multi-zone units from 2x9,000 Btu/h to 9x12,000 Btu/h. All YMGI DC Inverter mini-split units use energy efficient rotary compressors, and system efficiency ratings from 12-32 SEER.

## Reduce Your Carbon Footprint

YMGI HVAC systems are some of the most energy efficient products in the industry. Every detail of the Symphony Series systems, from the ductless design, zoning capabilities, DC Inverter technology, and even our U-TOUCH remote control, is designed to reduce energy consumption.

## Save Money

As much as 75% of the energy used in your home goes toward heating and cooling. In conventional central air systems, over 30% of the heat created escapes from the ducts before it ever enters a room. YMGI mini-split systems have no ductwork, so no energy is wasted.

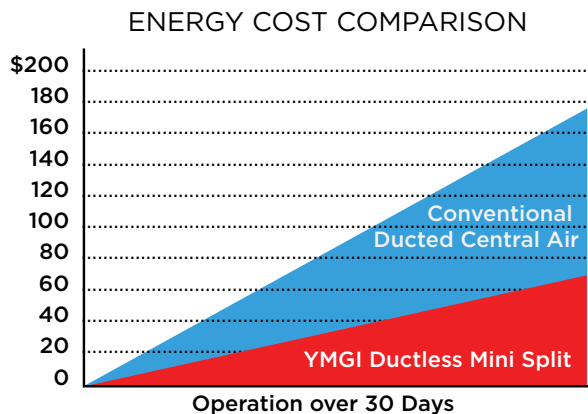

Because each zone or room is controlled separately, you only need to cool or heat a room when it is in use. With energy efficiency rating up to 32 SEER, YMGI DC Inverter systems not only make your room more comfortable, they also make your electric bills more affordable.

## Environmentally Friendly Inside & Out

### Eco-Friendly R410A Refrigerant

All SOLO and CHOIR systems use R-410A refrigerant, which is Hydrofluorocarbon (HFC) Free with zero ODP (Ozone Depletion Potential).

### RoHS Approved Materials

RoHS restricts the use of harmful substances commonly used in electronic equipment. YMGI only uses RoHS approved materials.

### Nitrogen-Protected Brazing

Reduced oxidation of joined metal parts, reliable performance and a longer unit life.

### Volatile Liquid Coil Cleaning

All component surfaces, joints, and corner weld are thoroughly cleaned to ensure safe clean equipment.

### Leakage Checked Refrigerant System

All refrigerant pipes, joints and components are checked for leakage during each step of manufacturing, ensuring every YMGI product is safe.

### Reusable Washable Filter and Advanced Filters

All YMGI systems come with a standard washable particulate filter. We also offer advanced filtration options, such as our active enzyme filter to eliminate bacteria, cold catalyst filter for removing pollen, dust, bacteria and harmful airborne chemicals from carpeting, flooring, paint and household cleaners, and our static electric filter for more thorough dust removal. With our selection of specialized filtration options, you can customize your indoor units to your air quality needs.

### Wide-Angle Air Spread and Long Air-throw

Louvers all for horizontal and vertical airflow, and quiet yet powerful multi speed fan allow for long air throw of over 20 feet, help conditioned air reach every corner of the room.

### Independent Dehumidification

YMGI units prioritize the reduction of humidity levels, to make heating and cooling more efficient.

### Random Pitch Cross-Flow Fan Wheel

YMGI's Random Pitch Cross-Flow Fan Wheel limits and offsets high pitched and low frequency sound generated during fan wheel rotation to provide whisper quite operation.

# Indoor Air, and your Health

- Indoor Air is up to 70 times more polluted than outdoor air.
- The average house generate up to 40 lbs of dust annually.
- Headaches and respiratory infections can be caused by poor indoor air quality.
- Allergies and asthma can be aggravated by poor indoor air quality.



## Breathe Healthier

Conventional ducted systems are notorious for poor air quality. Ductwork used in these systems create an ideal breeding ground for viruses, bacteria, and mold. When air passes through the ducting, dust, pollen and other allergens can be spread throughout a home, and adversely affect your health. Because YMGI mini-split systems have no ducting, your circulated air is cleaner and you can breathe healthier.

## Experience Maximum Air Filtration

Every YMGI indoor unit incorporates our washable and reusable particulate air filter. We also offer advanced filtration options, such as our active enzyme filter to eliminate bacteria, cold catalyst filter for removing pollen, dust, bacteria and harmful airborne chemicals from carpeting, flooring, paint and household cleaners, and our static electric filter for more thorough dust removal. With our selection of specialized filtration options, you can customize your indoor units to your air quality needs.



# YMGI Technology

## DC Inverter Technology - Continuously Adjusting for Profound Performance

Unlike conventional systems that cycle between on and off repeatedly, YMGI Symphony SOLO and CHOIR DC Inverter systems monitor room temperature and continuously adjust compressor speed up or down to provide precise temperature and humidity control. DC Inverter systems achieve this by converting alternating current (AC) to Direct Current (DC), modulating pulse width, and then directing the inverted current back to alternating current (AC) at the optimum frequency, precisely generating the thermal output needed, and maintaining the selected room temperature within very narrow ranges, while consuming substantially less energy. The incoming electrical power has a fixed frequency of 60 Hertz. By converter and inverter, the various current frequencies and voltages can be generated to supply the system, allowing the compressor to run at different speeds that suit the needs of various capacities and comfort levels with minimum energy consumption.

## Optimized System Design

Components are both individually and systematically optimized to ensure SOLO and CHOIR systems work in wide ranges of applications, and deliver the right amount of heating or cooling when you need it, and with maximum efficiency.

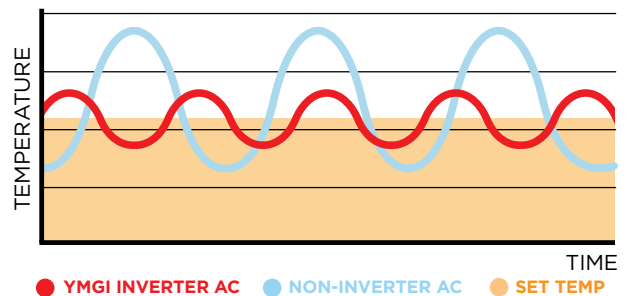

# SYMPHONY SOLAR (56) SERIES



## YMGI Symphony SOLAR 56 Series



### DC INVERTER

### Solar Assisted Single-Zone Wall-Mounted Mini-split

#### Solar Assisted Heating & Cooling

When the sun is shining, that's when you need your air conditioner the most. The (56) can be installed where AC electrical power is available, but the customer wants to utilize solar energy during the day to lower cooling and heating costs, without worrying about unit usage when it's cloudy or dark. With cooling capacities of 9k, 12k, 18k, 24k, 30k, and 36k, these single zone systems require 208-230 volt, 1 phase, 60Hz municipal power supply. The (56) SOLAR can be wired directly to an array of solar panels to offset power consumption. Depending on your installation configuration, you can achieve a SEER rating of up to 35.

On sunny days the (56) Solar HP will draw power from up to five  $\geq 300W$  solar panels. Municipal power allows the system to run when the weather is partly cloudy or overcast, and during night time operation.

No power is exported by the system, so no net metering agreement or special meter is required. The system can seamlessly utilize both power sources, with a bias towards using all available DC (solar) power.

#### YMGI DC INVERTER SOLAR

##### Single Zone-Wall Mounted Indoor Unit

The SOLO SOLAR 56 Series single zone mini-split quietly heats and cools solution with minimal environmental impact. The installation of the indoor unit uses an integrated mounting plate and only requires a 3" hole for conduit. The conduit houses all refrigerant pipes, electrical wiring and condensate drain hose. The wall unit has a motorized louver system that quietly distributes airflow evenly throughout the space.

#### YMGI DC INVERTER SOLO

The compact design allows for ground installation, or mounting in a variety of discreet locations, including on a wall, under a deck or even on a balcony.



# DC Inverter Mini System-Single Zone-(56) up to 32 SEER SOLAR PV Powered/Boosted Wall Mount 12 & 18K

- Optimized unique management on municipal AC and PV panel DC power
- Powered with PV panel DC power, backed up by municipal power
- Advanced temperature comfort and safety control
- Can be integrated to work with existing solar panels, if parameters matched
- Minimized municipal power usage. As low as 30W.
- R410A refrigerant and environment friendly materials, green products
- New solar panel installation eligible for Federal tax credit and/or State and/or utility company's rebate/incentive programs

AC Power Supply 208~240V,50/60HZ for Non-Stop Guaranteed Cooling/Heating								
Max. Solar Panel Qty.	W/V	3x250W/36V	4x250W/36V	4x250W/36V	4x300W/36V	4x300W/36V	4x300W/36V	
Model No.-System		WMMS-09KS-V2B(56)	WMMS-12KS-V2B(56)	WMMS-18KS-V2B(56)	WMMS-24KS-V2B(56)	WMMS-30KS-V2B(56)	WMMS-36KS-V2B(56)	
Model No.-Indoor Unit		WMMS-09ES-V2B(56)	WMMS-12ES-V2B(56)	WMMS-18ES-V2B(56)	WMMS-24ES-V2B(56)	WMMS-30ES-V2B(56)	WMMS-36ES-V2B(56)	
Model No.-Outdoor Unit		WMMS-09CS-V2B(56)	WMMS-12CS-V2B(56)	WMMS-18CS-V2B(56)	WMMS-24CS-V2B(56)	WMMS-30CS-V2B(56)	WMMS-36CS-V2B(56)	
Nominal Ton-Cooling	Ton	0.75	1	1.5	2	2.5	3	
Performance								
Capacity Rating	Cooling	Btu/h	9000	12000	18000	24000	30000	36000
		W	2600	3500	5200	7200	9000	10000
	Heating	Btu/h	10000	13000	20000	27000	34000	40000
		W	2800	3700	5400	7900	10000	11000
Noise	Indoor	dB(A)	≤40	≤42	≤44	≤46	≤47	≤48
	Outdoor	dB(A)	≤50	≤52	≤55	≤58	≤59	≤60
Air Circulation	cfm	265	324	441	618	706	735	
Suitable Area	sq.ft.	108~161	129~269	215~376	269~484	301~538	322~592	
EER	W/W	5.2	4.7	4.5	4.4	4.3	4.3	
SEER	Btu/h/w	35	34	34	33	33	32	
COP	W/W	5.8	5.2	4.9	4.8	4.7	4.7	
SCOP	Btu/h/w	39	37	37	36	36	36	
HSPF	Btu/h/w	12	12	13	14	14	14	
Recommended Ambient Temperature Ranges	Cooling	15 to 104 °F	15 to 104 °F	15 to 104 °F	15 to 104 °F	15 to 104 °F	15 to 104 °F	
	Heat Pump	-4 °F to 60 °F	-4 °F to 60 °F	-4 °F to 60 °F	-4 °F to 60 °F	-4 °F to 60 °F	-4 °F to 60 °F	
Design pressure	PSI	550 / 340	550 / 340	550 / 340	550 / 340	550 / 340	550 / 340	
Refrigerant Oil		VG74	VG74	VG74	VG74	VG74	VG74	
Refrigerant		R410A	R410A	R410A	R410A	R410A	R410A	
Compressor		TOSHIBA (ROTARY)	TOSHIBA (ROTARY)	TOSHIBA (ROTARY)	TOSHIBA (ROTARY)	TOSHIBA (ROTARY)	TOSHIBA (ROTARY)	
Liquid side		1/4"	1/4"	1/4"	1/4"	1/4"	1/4"	
Gas side		3/8"	1/2"	1/2"	1/2"	5/8"	5/8"	
Power Consumption								
Rated Power Input	W	450	750	950	1250	1350	1450	
Rated Current	A	2.05	3.41	4.32	5.68	6.12	6.60	
Dimensions								
Indoor Unit	NET	in.	30 1/2" x 10 1/4" x 8 9/32"	30 1/2" x 10 1/4" x 8 9/32"	39" x 12 5/8" x 8 9/32"	39" x 12 5/8" x 8 9/32"	42 1/2" x 12 5/8" x 9 7/16"	42 1/2" x 12 5/8" x 9 7/16"
	Package	in.	33 1/16" x 12 13/16" x 10 7/16"	33 1/16" x 12 13/16" x 10 7/16"	42 1/8" x 15 9/16" x 11 7/32"	42 1/8" x 15 9/16" x 11 7/32"	45 9/32" x 16 1/2" x 12 5/8"	45 9/32" x 16 1/2" x 12 5/8"
Outdoor Unit	NET	in.	31 1/8" x 10 1/4" x 21 9/32"	31 1/8" x 10 1/4" x 21 9/32"	33 15/32" x 11 13/16" x 27 9/16"	33 15/32" x 11 13/16" x 27 9/16"	34 1/16" x 12 3/16" x 27 15/16"	34 1/16" x 12 3/16" x 27 15/16"
	Package	in.	35 13/16" x 14 9/16" x 24 1/32"	35 13/16" x 14 9/16" x 24 1/32"	37 7/16" x 15 3/4" x 29 9/16"	37 7/16" x 15 3/4" x 29 9/16"	40 3/8" x 15 9/16" x 31 1/8"	40 3/8" x 15 9/16" x 31 1/8"
Weight								
Indoor Unit	Net/Gross	lbs	24.25 / 28.66	28.66 / 33	37.5 / 41.88	41.88 / 48.5	48.5 / 50.7	48.5 / 50.7
Outdoor Unit	Net/Gross	lbs	83.8 / 88.2	99.2 / 105.8	105.8 / 121.25	123.5 / 136.7	125.7 / 149.9	127.9 / 143.3

## Important Notes:

1. Performance without solar panel being installed is rated for matched system at standard conditions-cooling ID 80/67°F, OD 95°F; heating ID 70/60°F OD 47/43°F. Performance varies upon weather changes
2. Performance with solar panel being installed is rated at same ID conditions but OD STC conditions of 1000W/m<sup>2</sup> irradiance, 25°C (77°F) cell temperature. AM 1.5g spectrum according to EN 60904.3.
3. Watch unit operation during extreme weather conditions in summer and winter. After the unit is used for prolonged periods in extreme weather, unit may step into protection mode and stay idle.
4. Heating capacity and efficiency decrease as outdoor temperature drops. Cooling capacity and efficiency drop as outdoor temperatures rise.

# ALL DC MINI SPLIT

## Ultra-High SEER Solar Air Conditioner

The (86) Series All DC Mini Split Heat Pump lets you cool your home or office during the day for just pennies or even free. Designed to run completely off solar power, it can also be supplemented with grid power, when solar power can't provide 100% of the energy needed to run your system. The system can use 3 to 6 solar panels, with each panel generating 290 to 360w. When powered by batteries, it can run up to 8 hours, to keep you cool in the evening. Connecting the system to a converter and 220v AC power supply for power on overcast days, or at night. Attached to municipal power supply, the 22 SEER high efficiency system will save money while keeping you comfortable, even when the sun isn't shining. With solar power, the (86) Series Solar system can produce a SEER rating of up to 38.

## Great for Residential and Light Commercial

Heat or cool your home, office, or retail space with little or no energy costs. With capacities of 9k to 24k Btu/h, it can also be used to supplement systems in large homes or buildings.

All air conditioning systems consist of an outdoor condensing unit and an indoor evaporator unit. The basic difference between a mini-split and central system is that the evaporator unit of the central system is commonly installed in the basement or attic and uses metal or fiberglass ductwork to deliver warm or cool air to different rooms in your home. A central system requires space inside the walls between the joists for the ductwork, plus floor/wall/ceiling space to install the registers. These systems are often noisy and the ductwork is a haven for dust, germs, mold, bacteria, and insects.

The mini-split system is totally ductless. The indoor unit is mounted in the room you want to heat or cool, so no ductwork is required. The outdoor and indoor units are connected with small refrigerant copper pipes and wires that are wrapped tightly and securely through a 3" opening in the wall. Installation is faster, and easier than a conventional ducted system.



## Batteries Required

Like all DC-Inverter air conditioners, the YMG's (86) Series Solar HP compressor is powered by DC current. YMG's solar heat pump uses DC power generated by the solar panels, or from the system batteries. By using solar DC power instead of converting municipal AC power, this system can reduce daytime air conditioning or heating energy costs by as much as 100%.

The system can be installed for hybrid operation using municipal power and an AC to DC Converter. Most installations have solar power providing the energy needed run during daylight hours, supplemented by AC power at night or on overcast days.



## Simple To Install

The (86) Series Solar Heat Pump unit installs like a standard mini-split air conditioner. The solar panel array, batteries, and outdoor condenser unit all wire directly to the charge controller, which regulates power sent from the solar panels to the heat pump, to run the system, and recharging the batteries.

An optional AC to DC converter can be added to the system, so that municipal power can be used on overcast days, or during inclement weather.

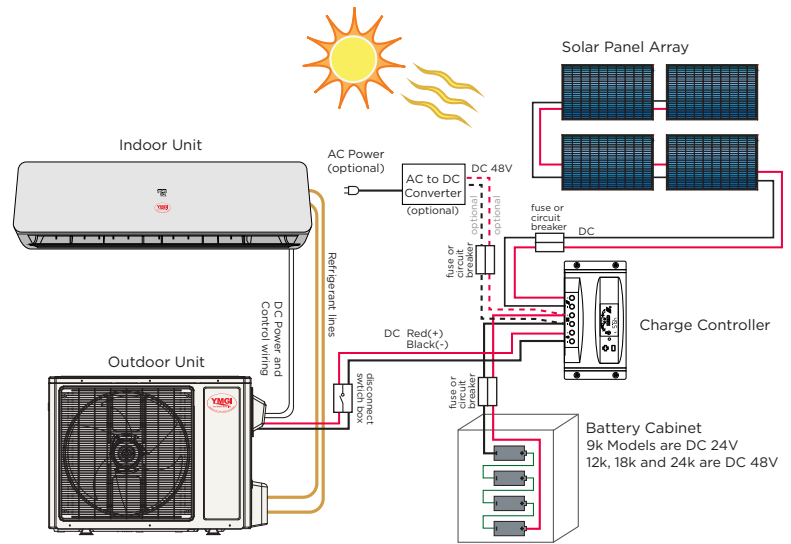

## Easy to Operate and Easy To Live With

Each YMG I mini-split indoor unit come with a remote control, that lets you select the operating thermal mode, fan speed, and oscillation of the air louvers, giving you total control of your environment. The remote also lets you program the start and stop time, and desired temperature. YMG I mini-split indoor units operate quietly, and have horizontal or vertical air directional louvers to evenly distribute conditioned air throughout the entire room. The outdoor units feature quiet operation, horizontal venting and a contemporary look.

## Products Perfect for Any Decor

YMG I SOLO and CHOIR systems offer a complete line of indoor units to cool or heat your rooms. Our attractive EW wall mounted units complement any decor. YMG I has indoor units that suit your needs and your taste.

On bright days, YMG I's (86) Series Solar HP can get up to 100% of its power from three  $\geq 300\text{W}$  solar panels. Up to six panels can be connected to the system increasing efficiency, and allowing it to run on 100% solar power when weather conditions are partly cloudy or overcast.

No power is exported by the system, so no special meter or net metering agreement with your utility company is required. The system can seamlessly utilize both power sources, with a bias towards using all available DC (solar) power.

# SYMPHONY SOLAR (86) SERIES



YMGi

Symphony SOLAR 86 Series



DC INVERTER

DC Powered Single-Zone  
Wall-Mounted Mini-split

### All DC Power

The all DC (86) Series is designed for use where AC electrical power is not available, and solar energy is the only available power source. Solar power is used to run the system, and excess generated power charges batteries that are used during overcast weather, or at night. By using solar DC power instead of converting municipal AC power, YMGi's (86) Series Solar HP can reduce daytime energy costs for air conditioning or heating by up to 100%.

On sunny days the (86) Series Solar HP can get 100% of its power from three  $\geq 300W$  solar panels. Up to six panels can be connected to the system increasing efficiency, and allowing it to run on 100% solar power even when partly cloudy or overcast. No power is exported by the system, so no special meter or net metering agreement is required.

The (86) system can be installed for hybrid operation by using an AC to DC Converter and municipal power.

### YMGi DC INVERTER SOLAR

#### Single Zone-Wall Mounted Indoor Unit

The installation of each indoor unit uses an integrated mounting plate and requires a 3" hole through the wall for conduit that houses all refrigerant pipes, electrical wiring and condensate drain hose. The wall unit has a motorized louver system that quietly distributes airflow evenly throughout the space.

### YMGi DC INVERTER SOLO

#### Single Zone-Outdoor Unit

With heating and cooling capacities of 09k, 12k, 18k, and 24k, the SOLO outdoor condensing unit is wired to a charge controller connected to a solar panel array and batteries. Depending on your installation configuration, with an optional AC converter, you can achieve a SEER rating of up to 38. The SOLAR SOLO compact design allows for ground installation, or mounting in a variety of locations, including on a wall, under a deck or even on a balcony.

# DC Inverter Mini System-Single Zone-(86) up to 38 SEER SOLAR PV Powered Wall Mount 09, 12, 18 & 24K

- Connects to 3 to 12 Panels (≥ Total 870W)
- Runs on Solar Power Only
- 9k, 12k, 18k and 24k BTU Cooling & Heating Capacities
- Solar Panels, Heat Pump, and Batteries Hook Directly to Charge Controller
- Can run up to 8 Hours on battery charge.

Wall Mounted Type DC Solar Air-Conditioner and Heat Pump							
Power Supply: 09k - 24VDC (22V - 28V)  12k-24k - 48VDC (42V to 60 V)							
<b>Models</b>	Model No.-System		WMMS-09KS-V24(86)	WMMS-12KS-V48(86)	WMMS-18KS-V48(86)	WMMS-24KS-V48(86)	
	Model No.-Indoor Unit		WMMS-09ES-V24(86)	WMMS-12ES-V48(86)	WMMS-18ES-V48(86)	WMMS-24ES-V48(86)	
	Model No.-Outdoor Unit		WMMS-09CS-V24(86)	WMMS-12CS-V48(86)	WMMS-18CS-V48(86)	WMMS-24CS-V48(86)	
<b>Capacity</b>	Cooling	Btu/h	9000	12000	18000	24000	
		W	2600	3500	5200	7200	
		Heating	Btu/h	10000	13000	20000	27000
			W	2800	3700	5400	7900
	Noise	Indoor	dB(A)	≤40	≤42	≤44	≤46
		Outdoor	dB(A)	≤50	≤52	≤55	≤58
	Air Circulation	cfm	265	324	441	618	
	Refrigerant		R134A	R134A	R134A	R134A	
	Compressor		Panasonic, DC 24V	Panasonic, DC 48V	Panasonic, DC 48V	Panasonic, DC 48V	
	Motor-ODU		DC Bushless	DC Bushless	DC Bushless	DC Bushless	
Motor-IDU		DC Bushless	DC Bushless	DC Bushless	DC Bushless		
<b>Power Consumption</b>	Power Input	W	500	750	1000	1300	
	Rated Current	A	20	16	21	27	
	Input Power	V	DC 24	DC 48	DC 48	DC 48	
Recommended Ambient Temperature Ranges	Cooling		15 to 104 °F	15 to 104 °F	15 to 104 °F	15 to 104 °F	
		Heat Pump	-4 °F to 60 °F	-4 °F to 60 °F	-4 °F to 60 °F	-4 °F to 60 °F	
	Solar charge controller	A	30 A Sold Separately	30 A Sold Separately	40 A Sold Separately	40 A Sold Separately	
<b>Dimensions</b>	Indoor Unit (With Controller)	NET	in.	30.5" x 10.25" x 8.28"	30.5" x 10.25" x 8.28"	39" x 12.6" x 8.28"	45.28" x 12.6" x 8.28"
		Package	in.	33" x 12.8" x 10.4"	33" x 12.8" x 10.4"	42.13" x 15.55" x 11.22"	42.13" x 15.55" x 11.22"
	Outdoor Unit	NET	in.	31.1" x 10.24" x 21.26"	31.1" x 10.24" x 21.26"	33.46" x 11.81" x 27.56"	33.46" x 11.81" x 27.56"
		Package	in.	35.83" x 14.57" x 24"	35.83" x 14.57" x 24"	37.4" x 15.75" x 29.53"	37.4" x 15.75" x 29.53"
	Solar Panel	NET	in.	58.27" x 26.77" x 5.51"	58.27" x 26.77" x 5.51"	58.27" x 26.77" x 5.51"	58.27" x 26.77" x 5.51"
		Shipping	in.	59.45" x 27.95" x 9.45"	59.45" x 27.95" x 9.45"	59.45" x 27.95" x 9.45"	59.45" x 27.95" x 9.45"
	Battery Cabinet	NET	in.	14.96" x 11" x 24.41"	19.7" x 16.54" x 24.4"	19.7" x 16.54" x 24.4"	24.41" x 23" x 24.41"
		Package	in.	17.32" x 13.40" x 29.53"	22" x 18.9" x 29.53"	22" x 18.9" x 29.53"	26.77" x 25.4" x 29.53"
<b>Weight</b>	Indoor Unit (w/ Controller)	Net/ Gross	lbs	24 / 29	28 / 33	37 / 42	42 / 46
	Outdoor Unit	Net/ Gross	lbs	84 / 88	99 / 106	106 / 121	123 / 137
	Solar Panel	Net/ Gross	lbs	66 / 84	88 / 123	110 / 128	132 / 165
	Battery	Net/ Gross	lbs	110 / 143	132 / 165	154 / 187	194 / 209
<b>Solar Panel and Battery Configuration - Expected to Work 4 hours at Night, after battery is fully charged during Daytime Operation.</b>							
Batteries	Output x Qty.		12 VDC x 2	12 VDC x 4	12 VDC x 4	12 VDC x 4	
Battery AH (12 DC each)	AH		60 x 2	100 x 4	150 x 4	200 x 4	
Solar panel specifications			24V/600W	48V/1000W	48V/1200W	48V/1800W	
EER	W/W		4.56	4.67	5.20	5.54	
	(Btu/h)/w		15.79	16.00	18.00	18.46	
<b>Solar Panel and Battery Configuration - Expected to Work 8 hours at Night, after battery is fully charged during Daytime Operation.</b>							
Batteries	Output x Qty.		12 VDC x 2	12 VDC x 4	12 VDC x 4	12 VDC x 8	
Battery AH (12 DC each)	AH		120 x 2	200 x 4	250 x 4	300 x 4	
Solar panel specifications			24V/300W*4	48V/300W*6	48V/300W*8	48V/300W*12	
EER	W/W		4.56	3.89	4.00	4.00	
	(Btu/h)/w		15.79	13.33	13.85	13.33	

### Important Notes:

1. Performance with solar panel being installed is rated at same ID conditions but OD STC conditions of 1000W/m<sup>2</sup> irradiance, 25°C (77°F) cell temperature. AM 1.5g spectrum according to EN 60904.3.
2. Watch unit operation during extreme weather conditions in summer and winter. After the unit is used for prolonged periods in extreme weather, unit may step into protection mode and stay idle.
3. Heating capacity and efficiency decrease as outdoor temperature drops. Cooling capacity and efficiency drop as outdoor temperatures rise.

# SOLAR VRF

## Solar Series -VRF

YMGI SOLAR SERIES VRF systems are so effective, your building will no longer require a furnace. At last, a single system can offer heating and cooling all year round.

SOLAR SERIES VRF systems are cutting edge Heat Pump technology. Using Variable Refrigerant Flow allows precise climate control, at high efficiency levels even in extreme temperature ranges (operating at 80% efficiency at -22° F).

## High Efficiency

SOLAR SERIES VRF systems are modular, and can be installed in modules of 3 units. Depending on the size of the PV Solar Panel array you install, SOLAR SERIES VRF systems have been tested up to 30 SEER.

## YMGI's VRF Systems

### What is Variable Refrigerant Flow?

Variable Refrigerant Flow, or VRF technology, is a heating and cooling system that routes 2 or 3-pipe refrigerant circuits from one outdoor unit to multiple indoor units (or zones) and can provide heating and cooling at the same time as different zones require. A Heat pump only VRF system (2 pipe circuit) can supply heating or cooling to multiple zones but all zones must be on the same setting. A Heat Recovery VRF system (3 pipe circuit) can supply heating and cooling to multiple zones simultaneously.

Traditional refrigerant systems are either "on" and operating at 100% capacity or "off". VRF systems utilizes inverter compressor technology, which provide variable speed operation.



### Why is this so important?

Because your HVAC systems seldom needs to provide 100% of the capacity they are designed for. Operating at such extremes can often lead to premature component or system failure.

VRF systems routinely operate at partial loads in the range of 30 to 70% which provides more consistent indoor temperatures, humidity levels, and energy efficiency.

Because of this partial-load capability, VRF systems are often more efficient, than commercial chiller/boiler systems while offering much greater design flexibility and using much less installation space.

# YMGI VRF Advantages

## Efficiency

VRF systems are better than chillers and much more efficient than standard splits and RTU's.

## Less Installation Space

VRF Systems can be install in smaller areas due to its smaller footprint thus taking up less square footage.

## Individual room control

Indoor units can heat and cool independently.

## Durability

VRF Systems are designed to withstand climates with large temperature extremes and operate for years. These systems have also been outlasting chillers.

## Excellent dehumidification

which is great for building preservation.

## Design flexibility

wall mounted, ceiling mounted, concealed non-ducted cassettes fit within acoustical ceiling tiles, and concealed ducted indoor units.

## Very low maintenance

(particularly when compared to central systems).

## Modular installation

these systems are great for retrofits, adding additional tonnage, and phased construction.

## No gas required; all electric.

No auxiliary heat strips needed.

## Suitable for a broad geographical range.

These systems perform to subzero temperatures(-22°F).



# Series

## More Installation Options

SOLAR SERIES VRF systems offer a variety of Indoor Unit options. If you're doing a retrofit, the SOLAR SERIES VRF can use our ducted Indoor Units and bolt onto existing duct work.



For new construction, we offer 4 different Indoor Units that allow you to go ductless, giving building occupants the flexibility to control their comfort at whatever level they would like in the room they are occupying.



# SOLAR SERIES HP MINI & MODULAR



## A VRF SYSTEM POWERED BY THE SUN

YMGI's Solar Series VRF systems are designed to be the most efficient heating and cooling systems on the market today. Available with Photo Voltaic Solar Panel Arrays from 5-25 panels, YMGI's Solar Series systems will save you money, and are an environmentally friendly way to heat and cool.



# UNIQUE FEATURES

both **Simple** & **Profound**  
YMGI Technology

## Optimized System Design

Components are both individually and systematically optimized to ensure YMGI VRF systems work in wide ranges of applications, and deliver the right amount of heating or cooling when you need it, and with maximum efficiency.

## Over-Current & Over-Heat

Built-in protection for over-current, over-heat and over-pressure, ensuring safe operation and longevity of components and the unit.

## Flexible Control Options

Your YMGI VRF comes with a standard remote controls, but can easily be configured to allow use of a wired or wireless thermostat, or network control.

## Thermostat and Network Control Ready

Optional Internal control board can be installed allowing your YMGI VRF Systems to work with any manufacturer's wall mounted thermostat.

Controllers can also be added, allowing up to 180 systems to be managed through a single PC interface. More units and properties can be added with additional control boards.

## Heating and Cooling Boost

This function boosts cooling or heating capacities at high compressor and fan speed. Rooms reach set temperatures as rapidly as possible.

## Quiet operation.

In a VRF system, the noisier condensing unit is typically outside, and the indoor air handlers are smaller and quieter than a traditional split system.



## Benefits

### Energy efficiency.

VRF systems use less energy for several reasons. The system is designed to provide exactly the amount of cooling needed for the current conditions, which means it runs less frequently and at a lower capacity. The VRF system is also designed to capture heat generated by the cooling process and reuse it in other areas that may need heating.

### Heat and cool simultaneously.

The VRF system captures residual heat absorbed from the air during the cooling process, and redirects that heat to other parts of the building that need heat. That means you can have air conditioning in the living room for a party, while you heat the bedroom where the baby is sleeping. Or you can have heat in the winter for cooler window offices, and air conditioning in the central conference room for a large meeting.

### Consistent comfort.

The VRF system's compressor can detect the precise requirements of each zone, and send the precise amount of refrigerant needed to do the job. As a result, each area of your space is consistently comfortable with well-controlled humidity and no hot or cold spots.

### Less Downtime.

Since the VRF system is designed to run only when needed and under partial-load conditions, there is less wear and tear on the parts. That means fewer breakdowns. If something goes wrong with one air handler, any others attached to the system are unaffected. That means your whole space won't be without air conditioning all at once.

### Requires Less Installation space.

Since the air handlers are smaller and VRF systems don't usually require ducts, they don't require as much wall and ceiling space for the equipment. That means you get to keep those gorgeous high ceilings in your apartment.

### Modern Controls.

For residences, you can take advantage of mobile control technology that lets you adjust temperature settings for each zone from your mobile device. For commercial settings, the VRF system's built-in controls may allow you to skip purchasing expensive building management software.

### Let's not forget maintenance

Like all HVAC systems, VRF systems need to be regularly inspected and maintained by a professional. With such a sophisticated system, you want to be sure to choose a provider with the right experience, and who can design a maintenance contract based on the needs of your system.

# Solar Series Heat Pump - Mini

Model	Unit	VRFO-36HP-S2B(55)5	VRFO-48HP-S2B(55)5
Cooling Capacity	Btu/h / kW	36,000 / 10.6	48,000 / 14
EER Without Solar Panels	Ducted	10.25	9.50
	Mixed Ducted	11.25	11.00
	Non-Ducted	12.25	12.50
SEER	Without Solar Panels	Ducted	16.25
		Mixed Ducted	17.25
		Non-Ducted	20.5
	With Solar Panels		26-40
			26-40
Heating Capacity	Btu/h / kW	45,000 / 13.2	54,000 / 15.8
HSPF	Ducted	10.20	10.20
	Mixed Ducted	10.60	10.60
	Non-Ducted	11.00	11.00
Air flow volume	CFM	3531	3884
Heating Capacities at Different OD Ambient Temperatures	47 °F	100% / 45,000	100% / 54,000
	17 °F	100% / 45,000	100% / 54,000
	-4 °F	100% / 45,000	100% / 54,000
	-22 °F	80% / 36,000	80% / 43,200
Sound Pressure Level	dB	53	54
Power Supply	V/Ø/Hz	208/230/1/60	208/230/1/60
Rated Input	kW	3.3	4.4
Power Input Cooling	Ducted	3.50	5.20
	Ductless	2.90	4.40
Power Input Heating	Ducted	3.70	5.30
	Ductless	3.30	5.40
MCA	A	35	35
MOP	A	60	60
Liquid pipe	in.	3/8	3/8
Gas Pipe	in.	5/8	5/8
Connection Method	-	Flare Connection	Flare Connection
Refrigerant	-	R410A	R410A
Compressor Manufacturer	-	GREE	GREE
Compressor Type	-	Two-stage VRF	Two-stage VRF
Compressor Quantity	No.	1	1
Motor Type	-	INVERTER	INVERTER
Fan Quantity	-	2	2
SEER (Ducted/Ductless IDUs)	-	16/18	16/18
Capacity Adjustment Range	%~%	15%~120%	15%~120%
Maximum drive IDU NO.	units	5	7
Max. Equivalent Connection Pipe Length	feet	393.7	393.7
Condenser Fin Color	-	Gold	Gold
Cooling Operation Ambient Temperature Range	°F	23° ~ 118°	23 ~ 118
Heating Operation Ambient Temperature Range	°F	-22° ~ 80.6°	-22 ~ 80.6
Refrigerant Charge	oz	229.3	229.3
Unit Dimensions (WxHxD)	in.	35 3/8 x 13 3/8 x 53	35 3/8 x 13 3/8 x 53
Net Weight	lbs	321.9	321.9
Low Ambient Cooling Function	-	YES	YES
Base Pan Heater	-	YES	YES
Maximum Number of IDU	Units	5	7
Recommended Solar Panels 300w	Pcs.	10-12	13-16

A	B	C	D	E
<b>VRFO-36HP-S2B(55)5 &amp; VRFO-48HP-S2B(55)5</b>				
35 3/8"	13 3/8"	53"	22 1/2"	14 7/8"

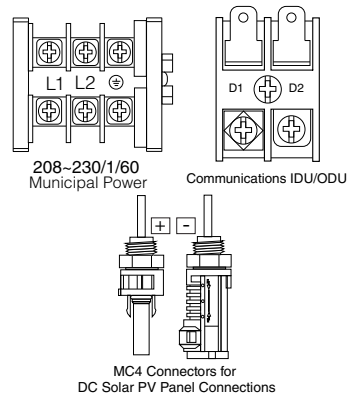
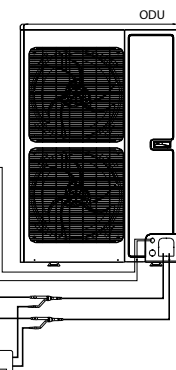
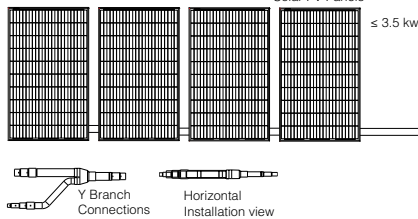
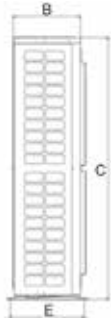

# Solar Series Heat Pump - Modular

Model	Unit	VRFO-96VP-S2C(55)5	VRFO-192VP-S2C(55)5	VRFO-288VP-S2C(55)5
Cooling Capacity	Btu/h	96,000	192,000	288,000
Cooling Capacity	kW	28.1	56.2	84.3
Heating Capacity	Btu/h	108,000	216,000	324,000
Heating Capacity	kW	31.6	63.2	94.8
Heating Capacities at Different OD Ambient Temperatures	47 °F	100% / 108,000	100% / 108,000	100% / 108,000
	17 °F	100% / 108,000	100% / 108,000	100% / 108,000
	-4 °F	100% / 108,000	100% / 108,000	100% / 108,000
	-22 °F	80% / 86,400	80% / 86,400	80% / 86,400
EER Ducted / Mixed / Non-Ducted		11.20 / 12.20 / 13.20	11.20 / 12.20 / 13.20	11.20 / 12.20 / 13.20
IEER Ducted / Mixed / Non-Ducted		20.00 / 22.50 / 25.00	20.00 / 22.50 / 25.00	20.00 / 22.50 / 25.00
COP 47 Ducted / Mixed / Non-Ducted		3.30 / 3.65 / 4.00	3.30 / 3.65 / 4.00	3.30 / 3.65 / 4.00
COP 17 Ducted / Mixed / Non-Ducted		2.25 / 2.33 / 2.40	2.25 / 2.33 / 2.40	2.25 / 2.33 / 2.40
Air flow volume	m³/h	14000	14000	14000
	CFM	8240	8240	8240
Sound Pressure Level	dB	61/71	61/71	61/71
ESP Power	WC	0.33"	0.33"	0.33"
Power Supply	V/Ø/Hz	208~230/3/60	2 x 208~230/3/60	3 x 208~230/3/60
Power Input Cooling	Ducted	kW		
	Ductless	kW	7.30	7.30
Power Input Heating	Ducted	kW		
	Ductless	kW	7.85	7.85
MCA	A	45	2 x 45	3 x 45
MOP	A	70	70	70
Gas pipe	in.	3/8	2 x 3/8	3 x 3/8
Liquid Pipe	in.	7/8	2 x 7/8	3 x 7/8
Connection Method	-	Brazing	Brazing	Brazing
Compressor Manufacturer	-	Hitachi	Hitachi	Hitachi
Compressor Type	-	Inverter Scroll Hermetic	Inverter Scroll Hermetic	Inverter Scroll Hermetic
Compressor Quantity	No.	2	4	6
Motor Type	-	Permanent Magnet Synchronous Motor	Permanent Magnet Synchronous Motor	Permanent Magnet Synchronous Motor
Fan Quantity	-	2	4	6
SEER (Without / With Solar Panels)	-	20 / 26-38	20 / 26-38	20 / 26-38
Capacity Adjustment Range	%~%	12%~120%	12%~120%	12%~120%
Maximum No. of IDU	units	20	40	60
Max. Equivalent Connection Pipe Length	feet	541-1/4	541-1/4	541-1/4
Condenser Fin Color	-	Gold	Gold	Gold
Cooling Operation Ambient Temp. Range	°F	14 ~ 126°	14 ~ 126°	14 ~ 126°
Heating Operation Ambient Temp. Range	°F	-22 ~75°	-22 ~75°	-22 ~75°
R410A Refrigerant Charge	oz	398	2 x 398	3 x 398
Unit Dimensions (WxD)	in.	52 3/4 x 63 1/4 x 30 1/8	52 3/4 x 63 1/4 x 30 1/8	52 3/4 x 63 1/4 x 30 1/8
Net Weight	lbs	749	2 x 749	3 x 749
Low Ambient Cooling Function		YES	YES	YES
Maximum Number of Solar Panels @ 300W	Pcs	32	32	32

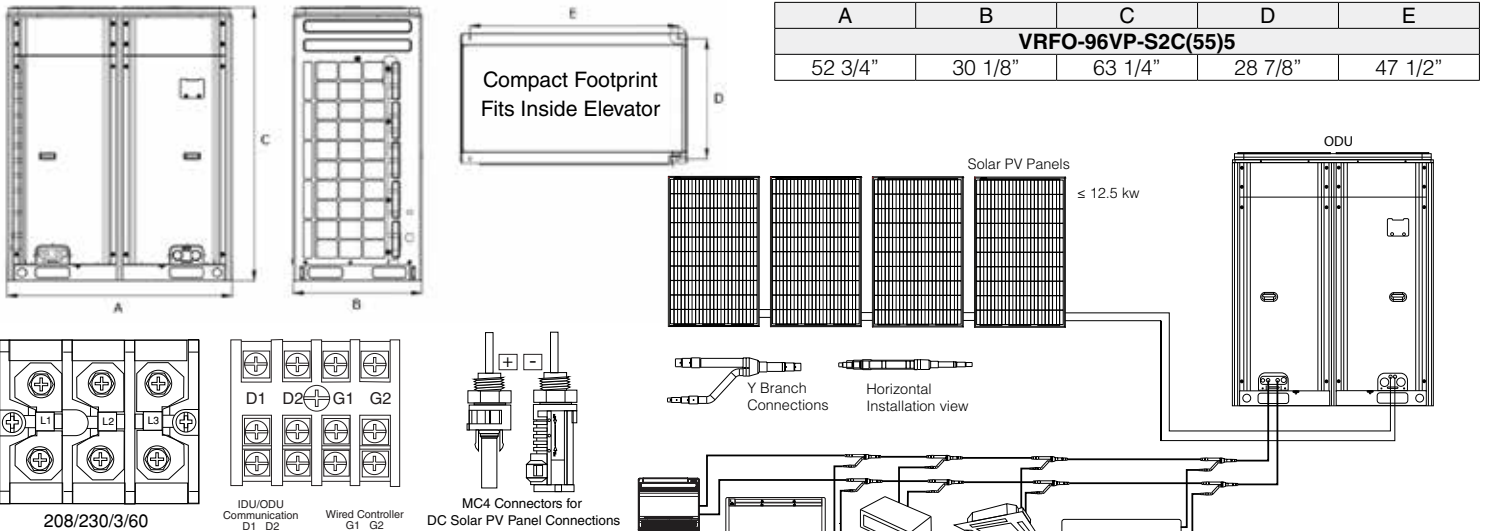

# Solar Series MonoCrystalline PV Module



- **Power Rating: 305W**
- **Frame color: Black**
- **Number of cells: 60 cells**
- **Frame Size: 35 mm**
- **Cell Type: Monocrystalline / N-type**
- **Tier 1**

## Safety

- Protection against salt mist corrosion
- Protection for ammonia corrosion
- Product is certified by UL1703

## Reliability

- Anti-PID products using advanced module technology
- World 1st company to pass “Thresher Test” and “On-site Power Measurement Validation” certificate
- Bankable products

## Performance

- Withstand high system voltage up to 1500V to save BoS Cost
- Outstanding power output capability at low irradiance
- Withstand up to 2400Pa wind and 5400Pa snow loads, long lasting

Characteristics	
Module Type	<b>SOLAR PANEL-PV-MC305BB</b>
Maximum Power at STC - $P_{mp}$ (W)	305
Open Circuit Voltage - $V_{oc}$ (V)	39.9
Short Circuit Current - $I_{sc}$ (A)	9.76
Maximum Power Voltage - $V_{mp}$ (V)	32.3
Maximum Power Current - $I_{mp}$ (A)	9.45
Module Efficiency STC- $\eta_m$ (%)	18.75
Power Tolerance (W)	(0,+4.99)
Maximum System Voltage (V)	1000 or 1500(UL)
Maximum Series Fuse Rating (A)	20
Fire Performance	Type2 or Type1(UL)
Electrical Characteristics (NOCT)	
Maximum Power at NOCT - $P_{mp}$ (W)	226
Open Circuit Voltage - $V_{oc}$ (V)	36.8
Short Circuit Current - $I_{sc}$ (A)	7.91
Maximum Power Voltage - $V_{mp}$ (V)	30.4
Maximum Power Current - $I_{mp}$ (A)	7.44
Temperature Characteristics	
$P_{max}$ Temperature Coefficient -0.38%/°C	-0.40 % / °C
$V_{oc}$ Temperature Coefficient -0.28 %/°C	-0.30 % / °C
$I_{sc}$ Temperature Coefficient +0.05 %/°C	0.04 % / °C
Operating Temperature -40~+85 °C	-0.42 % / °C
Mechanical Specifications	
External Dimensions	1640 x 992 x 35 mm / 64.57 x 39.06 x 1.37 inch
Weight	17.5 kg / 38.5 lbs
Solar Cells	Monocrystalline, 6 inch (60pcs.)
Front Glass	3.2 mm tempered glass, low iron
Frame	Anodized aluminium alloy
Junction Box	IP67
Output Cables	12AWG, cable length: 1000 mm
Connector	MC4 Compatible

STC: Irradiance 1000 W/m<sup>2</sup>, module temperature 25°C, AM=1.5  
 NOCT: Irradiance 800 W/m<sup>2</sup>, ambient temperature 20°C, wind speed : 1m/s  
 Specifications are subject to change without further notification.

# Solar Series PERC Monocrystalline PV Module

Mechanical Characteristics	
Dimensions (inches)	65 9/32" × 39 1/16" × 19/64"
Weight (lbs)	59.524
Front/ Back Tempered Glass (inches)	1/8"
Cell Arrangement	60 (6 × 10)
J-Box	IP67, Split J-Box
Connector	MC4 or MC4 Comparable
Cable Length	Anode 280mm, Cathode 150mm (custom-made)
Cable	TUV 4mm2
Packaging Configuration	30 pieces per pallet

## Solar Series Converting Unit

Specifications	
<b>Efficiency</b>	
Max. efficiency	97.6%
Utilization ratio of PV power	98.3%
<b>DC</b>	
Max. DC Input power	12.5kw
Max. DC Input voltage	900V
MPPT voltage range	540V~780V
Rated Input Voltage	650V
Current for DC protection	33A
<b>AC</b>	
Rated grid voltage	208Vac / 220Vac / 380Vac / 415Vac+PE+N
Rated grid frequency	50Hz / 60Hz
Allowable grid voltage range	180V ~ 460V
Protection value of grid peak current	85A
Power factor (max load)	>0.99
Max. total harmonic distortion (max load)	<4%
<b>Protection</b>	
DC input protection	Supported
Input over-under voltage protection	Supported
Output over current protection	Supported
Anti-islanding protection (Optional set)	Supported
Input over-under voltage protection (Optional set)	Supported
<b>Conventional Specifications</b>	
Operation temperature	-25 ~ 60°C / -13 ~ 140 °C
Cooling way	Forced Air-cooled
Max. operation altitude	3000m / 9842ft
Relative humidity (no condensation)	0~100%

# THE YMGI ADVANTAGE

## Ease of Installation

Easier to install than central systems, the hook-up between the VRF outdoor and indoor units generally requires only a three-inch hole through a wall for the conduit that contain the condensate drain hose, wires and refrigeration pipes. The mini outdoor units can be located up to 393.7 feet from the indoor units, and 3300 feet for modular outdoor units, making it possible to place the condensing unit where it can't be seen.

VRF outdoor condensing units are designed to be installed anywhere a central air conditioner or heat pump can be installed. The mini-split models can also be hung on a wall, placed on a balcony, below a deck, in a garage, and several places where a central air conditioner would be impossible to fit.

Professionally trained YMGI-certified technicians can properly install your VRF system, ensuring your system provides you with a lifetime of worry-free comfort.



## Technical Support

YMGI offers full technical support for all heating and cooling systems. If you have any questions about the operation of your unit, please consult your owner's manual. It will help you understand unit operation, various functions, and proper operation and maintenance of your system.

If your HVAC technician has any questions about installation or service, we provide technical assistance at **866-833-3138 ext.703**.



## Customer Service

When you or your technician calls YMGI hotlines, you will always talk to a live person. Along with our commitment to quality, customer service is the most important part of our business. Our goal is to exceed your expectations. We value each and every customer.

**YMGI Group**  
**YMGI HVAC & Solar Supply**  
601 Arrow Ln  
O'Fallon, Missouri 63366  
Phone: 1-866-833-3138  
Fax: 1-866-377-3355

**Sales:**  
[sales@ymgigroup.com](mailto:sales@ymgigroup.com)

**Technical Support:**  
[techsp@ymgigroup.com](mailto:techsp@ymgigroup.com)

**Service & Warranty:**  
[customerservice@ymgigroup.com](mailto:customerservice@ymgigroup.com)



## Warranty Overview

If you aren't satisfied, neither are we. Proper installation matters greatly to the performance and lifespan of your system. Having your system installed by a qualified HVAC installer is the first step.

If for any reason you do not receive a prompt response, you can call our 7/24-hour toll free number at 1-866-833-3138 ext.704 or email to us at [customerservice@YMGGroup.com](mailto:customerservice@YMGGroup.com).

To expedite service, please include a copy of your purchase invoice number, contractor installation invoice, unit model number and serial number, a full description of your problem, along with any photos or information that will help us resolve your issue as quickly as possible.

## Credentials & Certification

All YMG systems are ETL listed in both the U.S. and Canada. They are also certified by the AHRI and ENERGY STAR® to far exceed the current world standards for energy efficiency

## Tax Credits

When purchasing your YMG Symphony Series DC Inverter high energy efficiency system, don't forget to take advantage of any and all available federal tax credits. Many states and utility companies offer tax incentives. Be sure to check [YMGGroup.com](http://YMGGroup.com) to see what incentives are available in your area.

## Quality & More Stylish Looks

YMG units have clean, modern styling and complement any décor.

### Thoroughly Tested Before Packaging

Each YMG system is tested individually, and are packaged only after all safety, operational functions, features and cosmetic details have passed inspection. Our strict quality control tests following standards that are some of the highest of the industry.

### Reliable Quality

YMG products are designed using the latest technology and always keep the end user in mind. Using only highest quality parts, each YMG unit is built to last. Best of all, every YMG system is backed by our professional technical support and trouble-shooting guidance team.



# YMGI is Committed to Protecting the Environment by Offering a Wide Range of Energy Efficient Solar Assisted HVAC products.



YMGI is dedicated to designing, manufacturing and distributing the highest quality, energy saving and environmentally friendly air conditioner and heat pump products, while providing the best service and support to all of our customers. Our mission is to help build a sustainable, efficient and green world.

## YMGI Symphony-Ductless & Ducted Heat Pump & Heat Recovery:

- **Symphony SOLAR DC Inverter**  
(56) Single PV, (79) Single PH 12-18K Btu/h  
(86) Single Zone All DC 09-24K Btu/h  
(55) Multi Zone Solar VRF 3, 4, 8, 16, and 24 Ton.
- **Symphony SOLO DC Inverter**  
(57)2,3 Single Zone 16 SEER, 09-36K Btu/h  
(58)4, (78)1-Single Zone 18-23 SEER, 09-36K Btu/h
- **Symphony CHOIR DC Inverter**  
(46)2 DC Inverter Multiple Zone 15 SEER, 2x09K and 2x12K Btu/h  
(59)2S-DC Inverter Multiple Zone 16 SEER 6x09K to 9x09K Btu/h  
(59)4-DC Inverter Multiple Zone 21 SEER 2x09K to 5x12K Btu/h
- **Symphony VRF**  
DC Inverter HP, Heat Recovery, and Solar. Up to 64 zones.
- **Symphony HARMONY-Packaged Self-Contained**  
42"x16" PTAC/PTHP Electric Heater or Hot Water Coil, and VPAK
- **Symphony CONDUCTOR-Split Type Condensing Units**  
Side Discharge SHCR & YTAC

### YMGI Group

601 Arrow Ln, O'Fallon, MO 63366

[www.ymgigroup.com](http://www.ymgigroup.com)

Tel: 866-833-3138 • 917-868-4366

Fax: 866-377-3355

Email: [info@YMGIgroup.com](mailto:info@YMGIgroup.com)

Sales Representative or Distributor: